

HELİSEL DİŞLİ REDÜKTÖRLER

HELICAL GEARED MOTORS

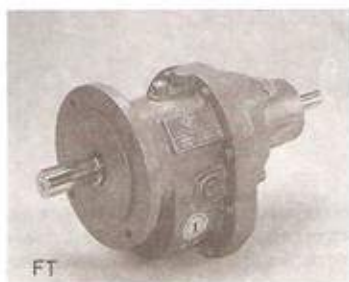

ÇEŞİTLİ ÜRÜNLERİMİZ



ÇEŞİTLİ ÜRÜNLERİMİZ



AA



FF

HELİSEL DİŞLİ REDÜKTÖRLER

Üretimini yaptığımız helisel dişli redüktörlerimiz A, F, T, FT, tipi serilerinde, motorlu ve motorsuz olmak üzere tek ve çift gövde akupeli olarak imal edilmektedir.

Bu tip redüktörlerimiz, ön ve arka kapak olmak üzere iki parçadan oluşmaktadır. Bu gövdeler gri pik tabir ettiğimiz (GG16-22) malzemenin yapıdır. Gövde cidar kalınlıklarının seçimi ve gövdede bulunan rulman yuvalarının rijitliğini sağlamak ve dışarıdan oluşan titreşimi içeriye iletmemek için rulman yuvaları içeriden federlerle desteklenmiştir. Dişli eksen aralarını oluşturan bu rulman yuvaları ve çevre bağlantı delikleri, CNC tabir edilen bilgisayarlı tezgahlarda tamamen otomatik olarak işlenirler.

Dişlilerimizin tamamı helisel dişlidir. Bu tip dişliler yapı gereği uygun beta açılarında, profilleri kaydırılarak, yuvalanma yöntemi ile açılırlar. Böylece diş diplerinin kalınlaşmasından dolayı dişlilerin daha fazla yük taşıması ve sessiz çalışması sağlanmış olur.

Dişli malzemesi olarak (Ç 8620-7131) sementasyon çelikleri kullanılır. Bu malzemeler daha sonra sementasyon işlemine tabi tutularak diş yüzeylerinin sert, iç yapılarının yumuşak olması sağlanır. Bu da ani torklarda esneme özellikleri nedeni ile dişlerde uzun bir çalışma ömrü sağlar. İşli işlemden 48 - 55 HRC sertleşmiş olan dişliler, rasplama tabir ettiğimiz alıştırma işlemine tabi tutularak uygun rulman yerleri ve pinyon geçme yuvaları taşlanır, montaja hazır hale getirilir.

Çıkış milleri (Ç 1050) tabir ettiğimiz malzemenin imal edilir. Bunlar CNC tezgahlarda hassas bir şekilde işlendikten sonra tüm yüzeyler, rulman ve keçe yerleri, toleranslarında olmak üzere taşlanır. Üzerindeki kamalar DIN 6885'e göre açılarak montaja hazır hale getirilir.

Yukarıda redüktör imalat yöntemlerimizle ilgili kısaca bilgiler verdik. Bu imalat esnasında en çok önem verdiğimiz diğer bir konuda kalite kontrolüdür. Bunun üzerinde önemle durduğumuz her redüktör, yağı doldurulduktan sonra ses ve moment iletim testine tabi tutulur.

Redüktörlerimizde, (akı bir istek gelmedikçe) ORS veya muadili rulmanlar kullanılır.

Yağlama sıvısı olarak 140 numara valvolin veya muadili bir yağ, şeffaf yağ gösterme tapalarına kadar doldurularak 3 ile 4 saat bekletildikten sonra, yağ sızmaları kontrol edilir ve ambalajlanarak sevki yapılır.

HELICAL GEARED MOTORS

The helical geared motors from our manufacture are produced in A, F, T, FT type serials with and without engines as single and double body accupled.

These type of our reducers are constituted in two parts, a cover on the front and rear. These bodies are produced from (GG16-22) materials we named gray cast iron. The roller housing are supported from inside with spring in order to choose the internal surface thickness and to provide the rigidity of the roller housing on the body, and further to avoid the transfer of the vibration from the outside. These roller housings constituting the gear axle distance and surround fixing holes are processed total otomatically through computered looms named CNC.

Our gears are full heliceil gears. The type gears opens with housing method throught gliding the profiles in suit beta angle accoring their structure. So it is provided that the gears support more load and work stiller because the tooth food gets thicker.

As gear material (C 8620-7131) cementation-steel is used. Later these materials are subject to a cementation procedure and it will provided that the outer surface are hard and the interior structures are flexible. And the elasticity characterist of the torques provides the gears a long working life. The gears which are hardened 48-55 HRC during the heating procedure are subject to a filing procedure namer rasping and the suit roller places and pinion transmission housing will be grindedanad brought in ready situation for mounting.

The outlet shafts are manufactured from materials named (C 1050). These will be processed sensitively at CNC looms and afterthen all surfaces, roller and felt places will be grinded with in their tolerances. The breech plugs on them will be prepared ready for mounting through opening according DIN 6885.

We have supplied you short informations about our manufacturing methods. One of the most important subjek for us during this manufacturing is the quality control. The procedure which we held for very important is that each reductor is subjected to a voice and moment transfer test after the oil-filling.

We are using ORS or similar roller for our reducers (if no otherwise requested)

As ciling fluit we are using 140 number vavolin or a similar oil. The oil is filled until the transparent oil display plugs and after waiting 3 or 4 hours the oil filtrating will be controlled. Afterthen they will packaged and delivered.





























TEKNİK BİLGİLER

YAĞ MİKTARLARI (LT veya Kg)

Explanatory Notes

Oil Quantity (LT or Kg)

REDÜKTÖR TİPİ GEAR UNIT TYPE									
	B3	B6	B7	B8	B5	V1	V3	V5	V6
A1	0,6	0,7	0,7	1				1,8	1,8
A2	1,2	1,4	1,4	2,1				4,5	4,5
A3	2	2,3	2,3	3,5				7	7
A4	3	3,3	3,3	5				10	10
A5	4	4,5	4,5	6,5				13,8	13,8
A6	5,4	5,6	5,6	8,5				19,5	19,5
A7	6,5	8	8	12				24	24
F1					0,6	1,8	1,8		
F2					1,2	3	3		
F3					2	4,6	4,6		
F4					3	6,5	6,5		
F5					4	8	8		
F6					5,4	14,5	14,5		
F7					6,5	24	24		
REDÜKTÖR TİPİ GEAR UNIT TYPE									
	B3	B6	B7	B8	B5	V1	V3	V5	V6
A12	0,6/1,2	1,4/0,7	1,4/0,7	2,1/1				4,5/1,8	4,5/1,8
A23	1,2/2	2,3/1,4	2,3/1,4	3,5/2,1				7/4,5	7/4,5
A34	2/3	3,3/2,3	3,3/2,3	5/3,5				7/10	7/10
A45	3/4	4,5/3,3	4,5/3,3	6,7/5				13,8/10	13,8/10
A56	5,4/4	5,6/4,5	5,6/4,5	8,4/6,7				19,5/13,8	19,5/13,8
A67	6,5/5,4	8/5,6	8/5,6	12/8,4				24/19,5	24/19,5
F12					1,2/0,6	3/1,8	3/1,8		
F23					2/1,2	4,6/3	4,6/3		
F34					2/3	6,5/4,6	6,5/4,6		
F45					3/4	8/6,5	8/6,5		
F56					5,4/4	14,5/8	14,5/8		
F67					6,5/5,4	24/14,5	24/14,5		
REDÜKTÖR TİPİ GEAR UNIT TYPE									
	B3	B6	B7	B8	B5	V1	V3	V5	V6
A11	0,6/0,6	0,7/0,7	0,7/0,7	1,0/1,0				1,8/1,8	1,8/1,8
A22	1,2/1,2	1,4/1,4	1,4/1,4	2,1/2,1				4,5/4,5	4,5/4,5
A33	2,0/2,0	2,3/2,3	2,3/2,3	3,5/3,5				7,0/7,0	7,0/7,0
A44	3,0/3,0	3,3/3,3	3,3/3,3	5,0/5,0				10,0/10,0	10,0/10,0
A55	4,0/4,0	4,5/4,5	4,5/4,5	6,7/6,7				13,8/13,8	13,8/13,8
A66	5,4/5,4	5,6/5,6	5,6/5,6	8,4/8,4				19,5/19,5	19,5/19,5
A77	6,5/6,5	7,0/7,0	7,0/7,0	9,5/9,5				24,0/24,0	24,0/24,0
F11					0,6/0,6	1,8/1,8	1,3/1,3		
F22					1,2/1,2	3,0/3,0	2,5/2,5		
F33					2,0/2,0	4,6/4,6	4,2/4,2		
F44					3,0/3,0	6,4/6,4	5,7/5,7		
F55					4,0/4,0	8,1/8,1	7,2/7,2		
F66					5,4/5,4	14,5/14,5	13,8/13,8		
F77					6,5/6,5	16/16	15/15		



HELİSEL DİŐLİ MOTORLU - MOTORSUZ REDÜKTÖR BAĐLANTI POZİSYONLARI

Mounting Positions - Helical Geared Motors - Helical Gear Units With Free Input Shaft

YATAY
POZİSYON

Horizontal
Position

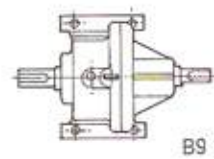
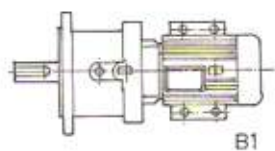
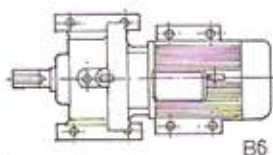
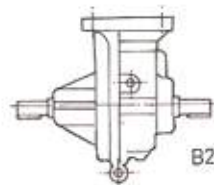
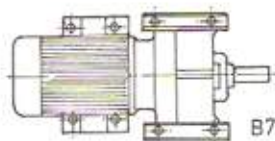
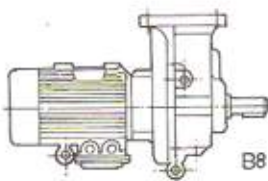
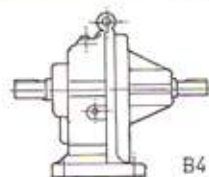
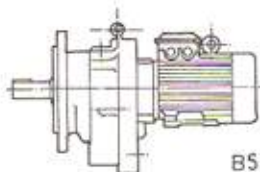
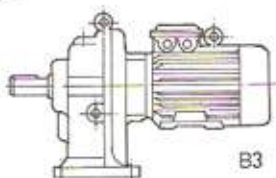

DİKEY
POZİSYON

Vertical
Position

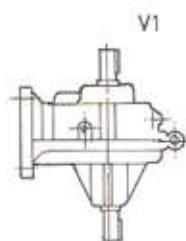
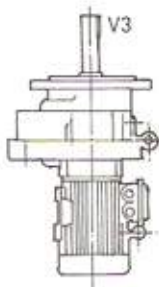
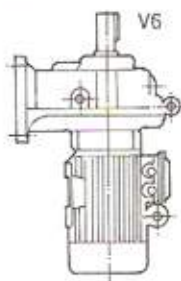

REDÜKTÖRLERİN SEÇİMİ

Selection Gearboxes

REDÜKTÖR SEÇİMİNDE SEMBOLLERİN ANLAMI

Meaning of the symbol in gearbox selection

A1	: Ayaklı Motorlu Tip	A1	: Fott mounting type with motor
A11	: Ayaklı Çift Gövdeli Motorlu Tip	A11	: Fott mounting double stage type with motor
A12	: Ayaklı Çift Gövdeli Motorlu Tip (Yüksek momentlerde)	A12	: Fott mounting double stage type with motor (High torque)
AT1	: Ayaklı Motorsuz Tip	AT1	: Fott mounting type without motor
AT11	: Ayaklı Çift Gövdeli Motorsuz Tip	AT11	: Fott mounting double stage type without motor
AT12	: Ayaklı Çift Gövdeli Motorsuz Tip (Yüksek momentlerde)	AT12	: Fott mounting double stage type without motor (High torque)
F1	: Flanşlı Motorlu Tip	F1	: Flange mounting type with motor
F11	: Flanşlı Çift Gövdeli Motorlu Tip	F11	: Flange mounting double stage type with motor
F12	: Flanşlı Çift Gövdeli Motorlu Tip (Yüksek momentlerde)	F12	: Flange mounting double stage type with motor (High torque)
FT1	: Flanşlı Motorsuz Tip	FT1	: Flange mounting type without motor
FT11	: Flanşlı Çift Gövdeli Motorsuz Tip	FT11	: Flange mounting double stage type without motor
FT12	: Flanşlı Çift Gövdeli Motorsuz Tip (Yüksek momentlerde)	FT12	: Flange mounting double stage type without motor (High torque)

YAĞ ÇEŞİTLERİ

TYPE OF OIL

REDÜKTÖR TİPİ TYPE OF GEARBOX	YAĞ CİNSİ TYPE OF OIL	ÇEVRE ISISI AMBIEN TEMPERATURES	BP	ESSO	MOBİL	SHELL
HELİSEL DİŞLİ REDÜKTÖR HELICAL SHAFT MOUNTING GEARBOXESS	MİNERAL YAĞ MINERAL OIL	-5 +40 (normal)	Energol GR-XP 220	Spartan EP 220	Mobil gear 630	Omala Oel 220
		-15 +25	Energol GR-XP 100	Spartan EP 150	Mobil gear 629	Omala Oel 100
	SENTETİK YAĞ SYNTHETIC OIL	-50 +15	Energol SHF 15	Univis J 13	D.T.E. 11	Tellus Oel T 15
		-25 +80	Energol SG-XP 220	Umlauföl S 220	Giygoyle 30	Tivela Oel WB

* -30 °C İla +60 °C'ı geçen ısılarda özel keçe kullanınız.

With ambient temperatures below -30 °C and above approx +60 °C shaft sealing rings of a special material quality must be used.



HELİSEL DİŞLİ REDÜKTÖRLER

0.75 - 30 - A2 - 80 M4B



Motor Type and Number of Poles

Gearboxes Type and Gearboxes sizes

Gearboxes output speed (n₂)

Power (Kw)

Üretimini yaptığımız sistemlerin, redüktör seçimi için, redüktörün çalışacağı ortam ve koşulların iyi bilinmesi gerekir. Gerekli çalışma ortamlarında verimli olabilecek redüktörün seçimi için, redüktör seçim tablolarında belirtilen, Servis faktörü(fs) değerlerinden faydalanılmalıdır. Redüktör seçim tablosunda belirtilen Servis faktörü değeri her türlü çalışma şartlarına göre istenen servis faktörü değerlerinden büyük veya eşit olmalıdır.

Redüktörün verimli olabilmesi için; özellikle redüktörün çalışacağı ortam ile redüktörün maruz kalacağı yük çeşidini çok iyi belirlenip, bu koşullara göre redüktör seçilmesi gereklidir. Yük çeşidi belirlenmesinde aşağıdaki tablodan faydalanılacağı gibi, çıkış momenti hesaplanarak seçilebilir.

For gearbox choose which knowing daily operations hours conditions and washing place. If the type of right gearbox is selected from gearbox chosen Table, and use the services factor(fs).

The services factor value, is painted gearbox chosen Table bigger than wishes services factor value or should be equivalent.

The choice of a suitable type and determination of optimum unit size is always reliable possible, if all aspects of the drive, as well as influences the drive will be exposed to, are carefully considered pervial of the following technical data will help greatly to Avoid errors and queries and to ensure long, Efficient and trouble free working life of the gearboxes.

M - 9550 ———— $\frac{P}{N2}$ Nnm

M = Moment
P = Güç (Kw)
n2 = Çıkış Hızı (d/dak)

M = Torque
P = Power (Kw)
n2 = Output Speed

R Uniform Load Hafif Yük	Kaldırma dişlileri, ince sıvı Pompaları	Lifter gear; Slight liquid pump
S Moderate Load Orta Darbeli Yük	Vinç Dişlileri, Yan döndürme dişlileri, Yarı Sıvı Pompalar, Tekstil Makinaları, Yağ Sanayii, Gıda Sanayii, Beyaz Eşya Sanayii, Hatte Makinaları, İnşaat Makinaları, Kauçuk Makinaları, Kimya Sanayii, Konveyörler.	Winch gears, flank reverse gears, pressure pump, textile machines, oil industry, nourishment industry, loundries and frozen industry, founpry machines, Building machinery, unvulcanizeal Rubber machines, chemical industry, dreggers.
T Heavy Shack Load Dadbeli Yük	Yürütme Dişlileri, Pompalar, Taş İşleme Makinaları, Gıda Sanayii, Hatte Makinaları, Kağıt Makinaları, Kauçuk Makinaları Hamur Karma Makinaları, Konveyörler, Yük Asansörleri	Travelling gear, pumps, stone and clay working machines, nourishment industry, founpry machines, paper machines, unvulcanized rubber machines, kneading and mixer machines, dreggers, elevator.



Klemens kutusu, Havalandırma, Yağ boşaltma ve Yağ Kontrol Civatalarının Pozisyonları:

Positions of air breather, oil drainage and oil checking screws:

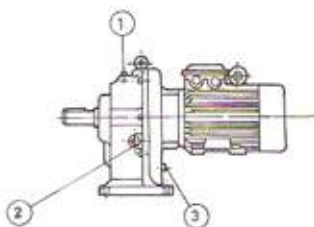
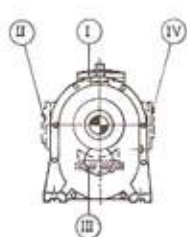

- 1 : HAVALANDIRMA CİVATASI
Screw of breather
2 : YAĞ KONTROL CAMI
Pane of oil checking
3 : YAĞ BOŞALTIMA CİVATASI
Screw of oil drainage

- I : ÜSTTE
Upper
II : SOLDA
Left hand side
III : ALTTA
Down
IV : SAĞDA
Right hand side

Not: REDÜKTÖRLER DİKEY POZİSYONDA İKEN YAĞ DOLDURMA V BOŞALTIMA CİVATALARININ YERLERİ DEĞİŞTİRİLİR.
Note: When the gearboxes mounted invetical position, oil filling and drainage screws should be substituted.

HELİSEL DİŞLİ REDÜKTÖR MONTAJ RESMİ

Mounting drawing of helical gearbox

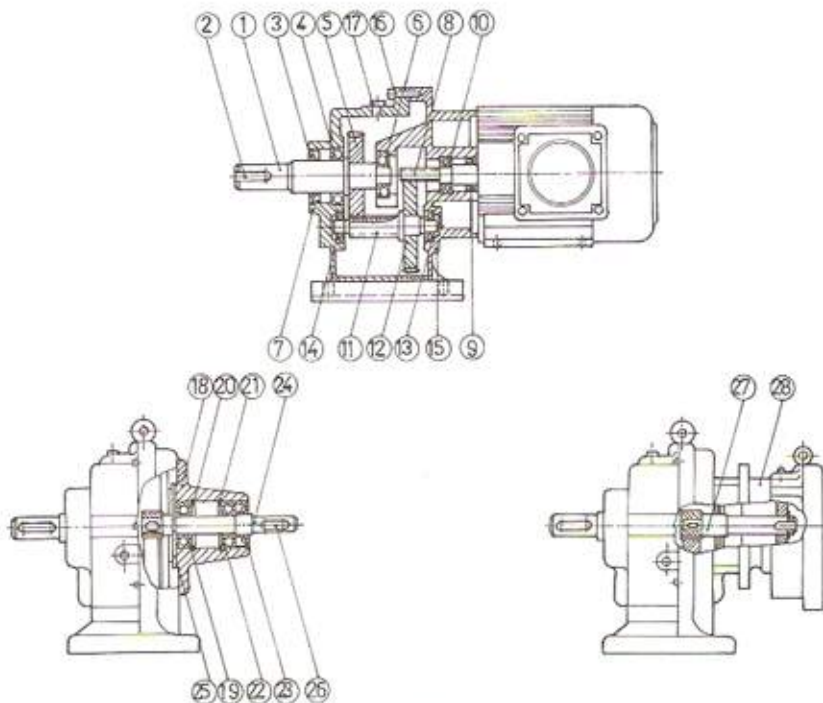

HELİSEL DİŞLİ REDÜKTÖRİN PARÇA LİSTESİ

Helical Gear Motors Part List

1	Çıkış mili	1	Output shaft
2	Kama	2	Key
3	Yağ keçesi	3	Shaft seal
4	Sabit Bilyalı Rulman	4	Output shaft bearing
5	Çıkış dişlisi	5	Driven gear
6	Sabit bilyalı rulman	6	Output shaft bearing
7	Gövde	7	Gear case
8	Rotor mili	8	Rotor shaft
9	Yağ keçesi	9	Seal
10	Sabit bilyalı rulman	10	Rotor shaft bearing
11	Pinyon mili	11	Driving pinion
12	Dişli	12	Driving gear
13	Sabit bilyalı rulman	13	Pinion shaft bearing
14	Sabit bilyalı rulman	14	Pinion shaft bearing
15	Kapak	15	Gear case cover
16	Altı köşe başlı civata	16	Hexagon screw
17	Havalandırma civatası	17	Vent screw
18	T gövde	18	Input bearing housing
19	Sabit bilyalı rulman	19	Grooved ball bearing
20	Segman	20	Circlip
21	Segman	21	Circlip
22	Sabit bilyalı rulman	22	Grooved ball bearing
23	Yağ keçesi	23	Shaft seal
24	Çalıştırıcı dişli mili	24	Input shaft, machined
25	Segman	25	Circlip
26	Kama	26	Key
27	Çalıştırıcı dişli mili	27	Input shaft
28	Aktarma gövde	28	Trans housing

REDÜKTÖRÜN MONTAJI YAPILIRKEN DİKKAT EDİLMESİ GEREKEN HUSUSLAR

Considerations For Mounting The Gearboxes

1- Redüktörün montajı tahrik edeceği makina ile aynı eksende çalışmalıdır.

Gearbox spindle and the machine spindle must be well alligned.

2- Redüktörün bağlandığı yüzey düz ve sağlam olmalıdır.

The base awwhich the gearbox bolted; must be smoth and streuth.

3- Redüktörün çıkış mili, tahrik edilecek makinanın ana mili çap olarak birbirini tamamlamalıdır.

The diamatar of both gearbox and the driven machine must be the same in size.

4- Kaplin bağlantılarında açılmal kaçıklıklara dikkat edilmelidir.

Care must be given to the angular off centers in clutch coverteous.

5- Kayış kasnak ve zincir tahriklerinde yüzeyler birbirine paralel çalışmalıdır.

Surfaces must be parallel to each ofhen in driving with chain and belt pulley.

6- Kayış ve zincir gerginliklerine dikkat edilmelidir.

Care must be given to stress of the belt and the chain.

7- Ani duruş ve kalkış yapan sistemlerde redüktör seçiminde yük katsayılarına dikkat edilmelidir.

Care must be given to the selection of the gearbox for the systems in stantaneously and stopping and staning-up

8- Redüktör ayak civataları iyi sıkılarak kontrol edilmeli ve redüktör işletmeye alınmalıdır.

After the ground-bolts has been well tighteved and checked; the gearbox must get into the operation.



KULLANIM TALİMATNAMESİ

- 1) Redüktör ilk işletmeye alınırken, elektrik bağlantısı ehliyetli bir kişiyi yaptırılmalıdır.
- 2) Redüktörün çalışma pozisyonuna göre delikli tapanın üste gelmesine dikkat edilmelidir.
- 3) Redüktör yere paralel pozisyonda, seviye göstergesine kadar 140 No. SAE Volvoline yağ ile doldurulmuştur.
- 4) Farklı pozisyonlarda bağlanacak redüktörlerde yağ seviyesine dikkat edilmelidir.
- 5) Redüktör ilk çalışmaya alındıktan 250 iş saati sonra, yağı değiştirilmelidir. Bu periyot, her 5000 iş saatinde bir tekrarlanmalıdır.
- 6) Redüktör rulmanlarının her 1000 iş saatinde bir bakımı yapılarak gerekli miktarda gres yağı sürülmelidir.

OPERATION INSTRUCTIONS

- 1) For installation and maintenance Please observe the " Operation instruction," It build the Professional electricity technician
- 2) The gearbox oil hole must be up right position.
- 3) Gearboxes are filled with " SAE Volvoline 140 " oil should be filled. Up the line on the indicator.
- 4) The amount of the oil must be taken into Consideration for the gear boxes wich is installed in the different position.
- 5) The oil of gearbox must be changed end of the first 250 business hours. Juch period must be repeated in each and every 5000 business hours.

GARANTİ KOŞULLARI

- 1) Tüm redüktörlerimiz imalattan kaynaklanan hatalara karşı bir yıl garantilidir.
- 2) Elektrik motorlarından dolayı meydana gelen arızalar garanti kapsamı dışındadır.
- 3) Redüktörlerin ilk işletmeye alınması kullanma talimatına uygun bir şekilde yapılmadığı takdirde garanti kapsamı sona erer.
- 4) Redüktörlere arıza durumunda ilk müdahalenin firmamız yetkililerince yapılması gereklidir. Bilgimiz dışında yapılan müdahaleler garanti kapsamını sona erdirir.
- 5) Seçilen redüktörün yapılacak işe uygun olmaması (Devir ve HP seçimi) sonucunda oluşacak arızalar garanti kapsamının dışındadır.
- 6) Sigortalanmamış redüktörlerin nakliye esnasında oluşabilecek arızaları, garanti kapsamı dışındadır. (Müşteri istemediği takdirde sigorta yapılmaz.)

WARRANTY

- 1) Remak offers quarentee of one year for the remak gearboxes.
- 2) Defects which have a wising out of electric motor are out of the quarentee.
- 3) The usage of the gearbox must be in compliance with the operation instruction otherwise warranty is ceased.
- 4) If the gearbox is full of obstacles it can be not repaired and you must apply to Remak.
- 5) If the purchaser is chose a wrong gearbox (a bout cycle and HP), this gearbox is out of quarentee.
- 6) The purchater isn't wanted to transport insuarence and the gearbox has damage to transport that gearbox is out of quarentee



A-F TİPİ REDÜKTÖR SEÇİM TABLOSU

P : Motor gücü

n2 : Çıkış hızı

M2 : Çıkış torku

i : Redüksiyon oranı

fs : Servis faktörü

A-F TYPES
SELECTION TABLE

P : Motor power

n2 : Output speed

M2 : Output torque

i : Ratio of the gearbox

fs : Operating factor

P Kw	n2 1/min	i	M2 Nm	TİP TYPE		fs
0,25	1	1/910	2388	A12/F12	80 M6A	0,8
	1,5	1/606,67	1592	A12/F12	80 M6A	0,9
	2	1/455	1194	A12/F12	80 M6A	1,1
	2,5	1/552	955	A12/F12	71 M4A	1,1
	3	1/460	796	A12/F12	71 M4A	1,1
	3,5	1/394,29	682	A12/F12	71 M4A	1,1
	4	1/345	597	A12/F12	71 M4A	1,2
	4,5	1/306,67	531	A11/F11	71 M4A	1
	5	1/276	478	A11/F11	71 M4A	1,1
	5,5	1/250,91	434	A11/F11	71 M4A	1,1
	6	1/230	398	A11/F11	71 M4A	1,2
	6,5	1/212,31	367	A11/F11	71 M4A	1,2
	7	1/197,14	341	A11/F11	71 M4A	1,2
	7,5	1/184	318	A11/F11	71 M4A	1,3
	8	1/172,50	298	A11/F11	71 M4A	1,3
	8,5	1/162,35	281	A11/F11	71 M4A	1,3
	9	1/153,33	265	A11/F11	71 M4A	1,3
	9,5	1/145,26	251	A11/F11	71 M4A	1,3
	10	1/138	239	A11/F11	71 M4A	1,3
	14	1/65	171	A1/F1	80 M6A	1,5
	16	1/56,88	149	A1/F1	80 M6A	1,5
	20,5	1/44,39	116	A1/F1	80 M6A	1,5
	22	1/62,73	109	A1/F1	71 M4A	1,1
	25	1/55,20	96	A1/F1	71 M4A	1,1
	25	1/36,40	96	A1/F1	80 M6A	1,6
	30	1/46	80	A1/F1	71 M4A	1,2
	30	1/30,33	80	A1/F1	80 M6A	1,7
	40	1/34,50	60	A1/F1	71 M4A	2
	47	1/29,36	51	A1/F1	71 M4A	2,1
	52	1/26,54	46	A1/F1	71 M4A	2,1
	60	1/23	40	A1/F1	71 M4A	2,2
	65	1/21,23	37	A1/F1	71 M4A	2,2
	82	1/16,83	29	A1/F1	71 M4A	2,3
	100	1/13,80	24	A1/F1	71 M4A	2,4
105	1/13,14	23	A1/F1	71 M4A	2,4	
130	1/10,62	18	A1/F1	71 M4A	2,5	
160	1/8,63	15	A1/F1	71 M4A	2,6	
190	1/7,26	13	A1/F1	71 M4A	2,7	
210	1/6,57	11	A1/F1	71 M4A	2,8	
265	1/5,21	9	A1/F1	71 M4A	2,9	
335	1/4,12	7	A1/F1	71 M4A	3	
400	1/3,45	6	A1/F1	71 M4A	3,1	
500	1/2,76	5	A1/F1	71 M4A	3,2	



A-F TİPİ REDÜKTÖR SEÇİM TABLOSU

P : Motor gücü

n2 : Çıkış hızı

M2 : Çıkış torku

i : Redüksiyon oranı

fs : Servis faktörü

A-F TYPES
SELECTION TABLE

P : Motor power

n2 : Output speed

M2 : Output torque

i : Ratio of the gearbox

fs : Operating factor

P Kw	n2 1/min	i	M2 Nm	TİP TYPE		fs
0,37	1	1/910	3534	A12/F12	80 M6B	1.5
	1,5	1/606,67	2356	A12/F12	80 M6B	1.5
	2	1/455	1767	A12/F12	80 M6B	1.5
	2,5	1/556	1413	A12/F12	71 M4B	1
	3	1/463,33	1178	A12/F12	71 M4B	1
	3,5	1/397,14	1010	A12/F12	71 M4B	1
	4	1/347,50	883	A11/F11	71 M4B	1
	4,5	1/308,89	785	A11/F11	71 M4B	1
	5	1/278	707	A11/F11	71 M4B	1.1
	5,5	1/252,73	642	A11/F11	71 M4B	1.1
	6	1/231,67	589	A11/F11	71 M4B	1.1
	6,5	1/213,85	544	A11/F11	71 M4B	1.1
	7	1/198,57	505	A11/F11	71 M4B	1.2
	7,5	1/185,33	471	A11/F11	71 M4B	1.2
	8	1/173,75	442	A11/F11	71 M4B	1.3
	8,5	1/163,53	416	A11/F11	71 M4B	1.3
	9	1/154,44	393	A11/F11	71 M4B	1.3
	9,5	1/146,32	372	A11/F11	71 M4B	1.3
	10	1/139	353	A11/F11	71 M4B	1.3
	14	1/65	252	A1/F1	80 M6B	1.1
	15	1/60,67	236	A2/F2	80 M6B	1.1
	16	1/56,88	221	A1/F1	80 M6B	1.1
	18	1/50,56	196	A2/F2	80 M4B	1.1
	20,5	1/44,39	172	A1/F1	80 M6B	1.2
	21,5	1/42,33	164	A2/F2	80 M6B	1.8
	22	1/63,18	161	A1/F1	71 M4B	1.2
	23	1/39,57	154	A1/F1	80 M6B	1.8
	25	1/55,60	141	A1/F1	71 M4B	1
	30	1/46,33	118	A1/F1	71 M4B	1.1
	33	1/27,58	107	A1/F1	80 M6B	1.4
	40	1/34,75	88	A1/F1	71 M4B	1.2
	47	1/29,57	75	A1/F1	71 M4B	1.2
	52	1/26,73	68	A1/F1	71 M4B	1.3
60	1/23,17	59	A1/F1	71 M4B	1.4	
65	1/21,38	54	A1/F1	71 M4B	1.4	
82	1/16,95	43	A1/F1	71 M4B	1.5	
100	1/13,90	35	A1/F1	71 M4B	1.6	
105	1/13,24	34	A1/F1	71 M4B	1.6	
130	1/10,69	27	A1/F1	71 M4B	1.7	
160	1/8,69	22	A1/F1	71 M4B	1.8	
190	1/7,32	19	A1/F1	71 M4B	1.9	
210	1/6,62	17	A1/F1	71 M4B	2.1	
265	1/5,25	13	A1/F1	71 M4B	2.2	
335	1/4,15	11	A1/F1	71 M4B	2.4	
400	1/3,48	9	A1/F1	71 M4B	2.5	
500	1/2,78	7	A1/F1	71 M4B	2.6	



A-F TİPİ REDÜKTÖR SEÇİM TABLOSU

P : Motor gücü
n2 : Çıkış hızı
M2 : Çıkış torku
i : Redüksiyon oranı
fs : Servis faktörü

A-F TYPES SELECTION TABLE

P : Motor power
n2 : Output speed
M2 : Output torque
i : Ratio of the gearbox
fs : Operating factor

P Kw	n2 1/min	i	M2 Nm	TİP TYPE		fs
0,55	1	1/910	5253	A23/F23	80 M6C	1,6
	1,5	1/606,67	3502	A23/F23	80 M6C	1,6
	2	1/455	2626	A23/F23	80 M6C	1,6
	2,5	1/558	2101	A23/F23	80 M4A	1,1
	3	1/465	1751	A23/F23	80 M4A	1,1
	3,5	1/398,57	1501	A23/F23	80 M4A	1,1
	4	1/348,75	1313	A22/F22	80 M4A	1
	4,5	1/310	1167	A22/F22	80 M4A	1
	5	1/279	1051	A22/F22	80 M4A	1,1
	5,5	1/253,64	955	A22/F22	80 M4A	1,1
	6	1/232,50	875	A22/F22	80 M4A	1,2
	6,5	1/214,62	808	A22/F22	80 M4A	1,2
	7	1/199,29	750	A22/F22	80 M4A	1,2
	7,5	1/186	700	A22/F22	80 M4A	1,2
	8	1/174,38	657	A22/F22	80 M4A	1,3
	8,5	1/164,12	618	A22/F22	80 M4A	1,3
	9	1/155	584	A22/F22	80 M4A	1,3
	9,5	1/146,84	553	A22/F22	80 M4A	1,3
	10	1/91	525	A2/F2	80 M6C	1,1
	13	1/70	404	A3/F3	80 M6C	2,2
	15	1/60,67	350	A3/F3	80 M6C	2,2
	15	1/60,67	350	A2/F2	80 M6C	1,1
	19	1/47,89	276	A3/F3	80 M6C	2,2
	19	1/47,89	276	A2/F2	80 M6C	1,2
	23	1/39,57	228	A2/F2	80 M6C	1,2
	23	1/60,65	228	A2/F2	80 M4A	1
	28	1/32,50	188	A2/F2	80 M6C	1,2
	30	1/46,50	175	A2/F2	80 M4A	1
	35	1/26	150	A2/F2	80 M6C	1,3
	35	1/39,86	150	A2/F2	80 M4A	1,1
	40	1/34,88	131	A2/F2	80 M4A	1,2
	45	1/31	117	A2/F2	80 M4A	1,2
	50	1/27,90	105	A2/F2	80 M4A	1,3
	55	1/25,36	96	A2/F2	80 M4A	1,3
	60	1/23,25	88	A2/F2	80 M4A	1,4
	70	1/19,93	75	A2/F2	80 M4A	1,5
	75	1/18,60	70	A2/F2	80 M4A	1,6
	80	1/17,44	66	A2/F2	80 M4A	1,6
	100	1/13,95	53	A1/F1	80 M4A	1,2
	105	1/13,29	50	A1/F1	80 M4A	1,2
130	1/10,73	40	A1/F1	80 M4A	1,9	
160	1/8,72	33	A1/F1	80 M4A	2,1	
190	1/7,34	28	A1/F1	80 M4A	1,9	
210	1/6,64	25	A1/F1	80 M4A	2,6	
265	1/5,26	20	A1/F1	80 M4A	3,3	
335	1/4,16	16	A1/F1	80 M4A	2,1	
400	1/3,49	13	A1/F1	80 M4A	3,5	
500	1/2,79	11	A1/F1	80 M4A	3,5	



A-F TİPİ REDÜKTÖR SEÇİM TABLOSU

P : Motor gücü
n2 : Çıkış hızı
M2 : Çıkış torku
i : Redüksiyon oranı
fs : Servis faktörü

A-F TYPES
SELECTION TABLE

P : Motor power
n2 : Output speed
M2 : Output torque
i : Ratio of the gearbox
fs : Operating factor

P Kw	n2 1/min	i	M2 Nm	TİP TYPE		fs
0,75	1	1/925	7163	A23/F23	90 S6A	1,7
	1,5	1/616,67	4775	A23/F23	90 S6A	1,7
	2	1/700	3581	A23/F23	80 M4B	1,1
	2,5	1/560	2865	A23/F23	80 M4B	1,1
	3	1/466,67	2388	A23/F23	80 M4B	1,1
	3,5	1/400	2046	A23/F23	80 M4B	1,1
	4	1/350	1791	A23/F23	80 M4B	1,2
	4,5	1/311,11	1592	A23/F23	80 M4B	1,2
	5	1/280	1433	A23/F23	80 M4B	1,3
	5,5	1/254,55	1302	A22/F22	80 M4B	1
	6	1/233,33	1194	A22/F22	80 M4B	1
	6,5	1/215,38	1102	A22/F22	80 M4B	1
	7	1/200	1023	A22/F22	80 M4B	1
	7,5	1/186,67	955	A22/F22	80 M4B	1,1
	8	1/175	895	A22/F22	80 M4B	1,1
	8,5	1/164,71	843	A22/F22	80 M4B	1,1
	9	1/155,56	796	A22/F22	80 M4B	1,2
	9,5	1/147,37	754	A22/F22	80 M4B	1,2
	13	1/71,15	551	A3/F3	90 S6A	2,1
	15	1/61,67	478	A3/F3	90 S6A	2,1
	15	1/61,67	478	A2/F2	90 S6A	1,1
	17	1/82,35	421	A2/F2	80 M4B	0,9
	19	1/48,68	377	A3/F3	90 S6A	2,1
	19	1/48,68	377	A2/F2	90 S6A	1,2
	23	1/40,22	311	A2/F2	90 S6A	1,2
	23	1/60,87	311	A2/F2	80 M4B	1
	28	1/33,04	256	A2/F2	90 S6A	1,3
	29	1/48,28	247	A2/F2	80 M4B	1
	35	1/26,43	205	A2/F2	90 S6A	1,4
	35	1/40	205	A2/F2	80 M4B	1,1
	43	1/32,56	167	A2/F2	80 M4B	1,2
	51	1/27,45	140	A2/F2	80 M4B	1,3
	56	1/25	128	A2/F2	80 M4B	1,3
	60	1/23,33	119	A2/F2	80 M4B	1,4
	70	1/20	102	A2/F2	80 M4B	1,5
	75	1/18,67	96	A2/F2	80 M4B	1,5
	80	1/17,50	90	A2/F2	80 M4B	1,6
	100	1/14	72	A1/F1	80 M4B	1,2
	105	1/13,33	68	A1/F1	80 M4B	1,2
	130	1/10,77	55	A1/F1	80 M4B	1,3
160	1/8,75	45	A1/F1	80 M4B	1,4	
190	1/7,37	38	A1/F1	80 M4B	1,5	
210	1/6,67	34	A1/F1	80 M4B	1,6	
265	1/5,28	27	A1/F1	80 M4B	1,7	
335	1/4,18	21	A1/F1	80 M4B	1,8	
400	1/3,50	18	A1/F1	80 M4B	2	
500	1/2,80	14	A1/F1	80 M4B	2,2	

A-F TİPİ REDÜKTÖR SEÇİM TABLOSU

P : Motor gücü
n2 : Çıkış hızı
M2 : Çıkış torku
i : Redüksiyon oranı
fs : Servis faktörü

A-F TYPES
SELECTION TABLE

P : Motor power
n2 : Output speed
M2 : Output torque
i : Ratio of the gearbox
fs : Operating factor

P Kw	n2 1/min	i	M2 Nm	TİP TYPE		fs
	1	1/935	10505	A34/F34	90 L6B	1.8
	1.5	1/623,33	7003	A34/F34	90 L6B	1.8
	2	1/467,50	5253	A34/F34	90 L6B	1.8
	2,5	1/374	4202	A34/F34	90 L6B	1.9
	3	1/470	3502	A34/F34	90 S4A	1.1
	3,5	1/402,86	3001	A34/F34	90 S4A	1.1
	4	1/352,50	2626	A34/F34	90 S4A	1.2
	4,5	1/313,33	2334	A34/F34	90 S4A	1.2
	5	1/282	2101	A33/F33	90 S4A	0.9
	5,5	1/256,36	1910	A33/F33	90 S4A	1
	6	1/235	1751	A33/F33	90 S4A	1.1
	6,5	1/216,92	1616	A33/F33	90 S4A	1.1
	7	1/201,43	1501	A23/F23	90 S4A	0.9
	7,5	1/188	1401	A23/F23	90 S4A	1
	8	1/176,25	1313	A23/F23	90 S4A	1.1
	8,5	1/165,88	1236	A23/F23	90 S4A	1.2
	9	1/156,67	1167	A23/F23	90 S4A	1.2
	9,5	1/148,42	1106	A23/F23	90 S4A	1.2
	10	1/141	1051	A23/F23	90 S4A	1.2
	13,5	1/69,26	778	A3/F3	90 L6B	1
	15,5	1/60,32	678	A3/F3	90 L6B	1
	17	1/55	618	A3/F3	90 L6B	1
1,1	20	1/46,75	525	A3/F3	90 L6B	1.1
	20	1/70,50	525	A3/F3	90 S4A	0.9
	25	1/37,40	420	A3/F3	90 L6B	1.2
	25	1/56,40	420	A3/F3	90 S4A	0.9
	30	1/31,17	350	A3/F3	90 L6B	1.3
	30	1/47	350	A3/F3	90 S4A	1
	38	1/37,11	276	A3/F3	90 S4A	1.1
	45	1/31,33	233	A3/F3	90 S4A	1.2
	50	1/28,20	210	A3/F3	90 S4A	1.3
	60	1/23,50	175	A3/F3	90 S4A	1.4
	65	1/21,69	162	A3/F3	90 S4A	1.5
	70	1/20,14	150	A3/F3	90 S4A	1.6
	75	1/18,80	140	A3/F3	90 S4A	1.6
	80	1/17,63	131	A3/F3	90 S4A	1.7
	90	1/15,67	117	A3/F3	90 S4A	1.8
	100	1/14,10	105	A2/F2	90 S4A	1
	126	1/11,19	83	A2/F2	90 S4A	1.1
	157	1/8,98	67	A2/F2	90 S4A	1.2
	190	1/7,42	55	A2/F2	90 S4A	1.4
	226	1/6,24	46	A2/F2	90 S4A	1.6
	246	1/5,73	43	A2/F2	90 S4A	1.7
	310	1/4,55	34	A2/F2	90 S4A	1.8
	349	1/4,04	30	A2/F2	90 S4A	2
	428	1/3,29	25	A2/F2	90 S4A	2.2
	495	1/2,85	21	A2/F2	90 S4A	2.4



A-F TİPİ REDÜKTÖR SEÇİM TABLOSU

P : Motor gücü
n2 : Çıkış hızı
M2 : Çıkış torku
i : Redüksiyon oranı
fs : Servis faktörü

A-F TYPES
SELECTION TABLE

P : Motor power
n2 : Output speed
M2 : Output torque
i : Ratio of the gearbox
fs : Operating factor

P Kw	n2 1/min	i	M2 Nm	TİP TYPE		fs
1,5	1	1/940	14325	A34/F34	100 L6A	1,8
	1,5	1/626,67	9550	A34/F34	100 L6A	1,8
	2	1/470	7163	A34/F34	100 L6A	1,8
	2,5	1/568	5730	A34/F34	90 L4A	1,1
	3	1/473,33	4775	A34/F34	90 L4A	1,1
	3,5	1/405,71	4093	A34/F34	90 L4A	1,1
	4	1/355	3581	A34/F34	90 L4A	1,2
	4,5	1/315,56	3183	A34/F34	90 L4A	1,2
	5	1/284	2865	A33/F33	90 L4A	1
	5,5	1/258,18	2605	A33/F33	90 L4A	1
	6	1/236,67	2388	A33/F33	90 L4A	1
	6,5	1/218,46	2204	A33/F33	90 L4A	1
	7	1/202,86	2046	A33/F33	90 L4A	1,1
	7,5	1/189,33	1910	A33/F33	90 L4A	1,1
	8	1/177,50	1791	A33/F33	90 L4A	1,1
	8,5	1/167,06	1685	A33/F33	90 L4A	1,1
	9	1/157,78	1592	A33/F33	90 L4A	1,2
	9,5	1/149,47	1508	A33/F33	90 L4A	1,2
	10	1/142	1433	A33/F33	90 L4A	1,3
	13,5	1/69,63	1061	A4/F4	100 L6A	1,8
	13,5	1/69,63	1061	A3/F3	100 L6A	1,1
	15,5	1/60,65	924	A4/F4	100 L6A	1,9
	15,5	1/60,65	924	A3/F3	100 L6A	1,2
	20	1/47	716	A4/F4	100 L6A	1,9
	21	1/67,62	682	A3/F3	90 L4A	1
	23	1/40,87	623	A3/F3	100 L6A	1,4
	24	1/59,17	597	A3/F3	90 L4A	1
	29	1/32,41	494	A3/F3	100 L6A	1,4
	30	1/47,33	478	A3/F3	90 L4A	1,1
	38	1/37,37	377	A3/F3	90 L4A	1,2
	45	1/31,56	318	A3/F3	90 L4A	1,3
	50	1/28,40	287	A3/F3	90 L4A	1,4
	60	1/23,67	239	A3/F3	90 L4A	1,4
	65	1/21,85	220	A3/F3	90 L4A	1,5
	70	1/20,29	205	A3/F3	90 L4A	1,6
	75	1/18,93	191	A3/F3	90 L4A	1,6
	80	1/17,75	179	A3/F3	90 L4A	1,7
	90	1/15,78	159	A3/F3	90 L4A	1,8
	100	1/14,20	143	A2/F2	90 L4A	1,2
	126	1/11,27	114	A2/F2	90 L4A	1,3
157	1/9,04	91	A2/F2	90 L4A	1,4	
190	1/7,47	75	A2/F2	90 L4A	1,5	
226	1/6,28	63	A2/F2	90 L4A	1,6	
246	1/5,77	58	A2/F2	90 L4A	1,7	
310	1/4,58	46	A2/F2	90 L4A	1,9	
349	1/4,07	41	A2/F2	90 L4A	2,2	
428	1/3,32	33	A2/F2	90 L4A	2,4	
495	1/2,87	29	A2/F2	90 L4A	2,6	



A-F TİPİ REDÜKTÖR SEÇİM TABLOSU

P : Motor gücü

n2 : Çıkış hızı

M2 : Çıkış torku

i : Redüksiyon oranı

fs : Servis faktörü

A-F TYPES SELECTION TABLE

P : Motor power

n2 : Output speed

M2 : Output torque

i : Ratio of the gearbox

fs : Operating factor

P Kw	n2 1/min	i	M2 Nm	TİP TYPE		fs
2.2	1	1/945	21010	A45/F45	112 M6A	1.8
	1,5	1/946,67	14007	A45/F45	100 L4A	1.1
	2	1/710	10505	A45/F45	100 L4A	1.1
	2,5	1/568	8404	A45/F45	100 L4A	1.1
	3	1/473,33	7003	A45/F45	100 L4A	1.2
	3,5	1/405,71	6003	A45/F45	100 L4A	1.2
	4	1/355	5253	A45/F45	100 L4A	1.2
	4,5	1/315,56	4669	A45/F45	100 L4A	1.3
	5	1/284	4202	A44/F44	100 L4A	0.9
	5,5	1/258,18	3820	A44/F44	100 L4A	0.9
	6	1/236,67	3502	A44/F44	100 L4A	1
	6,5	1/218,46	3232	A44/F44	100 L4A	1
	7	1/202,86	3001	A34/F34	100 L4A	1
	7,5	1/189,33	2801	A34/F34	100 L4A	1
	8	1/177,50	2626	A34/F34	100 L4A	1.1
	8,5	1/167,06	2472	A34/F34	100 L4A	1.1
	9	1/157,78	2334	A34/F34	100 L4A	1.1
	9,5	1/149,47	2212	A34/F34	100 L4A	1.2
	10	1/142	2101	A34/F34	100 L4A	1.2
	13	1/72,69	1616	A5/F5	112 M6A	1.9
	13	1/72,69	1616	A4/F4	112 M6A	1.1
	15	1/63	1401	A5/F5	112 M6A	1.9
	15	1/63	1401	A4/F4	112 M6A	1.1
	20	1/47,25	1051	A5/F5	112 M6A	1.9
	20	1/47,25	1051	A4/F4	112 M6A	1.2
	21	1/67,62	1000	A4/F4	100 L4A	0.8
	24	1/39,36	875	A4/F4	112 M6A	1.2
	24	1/59,17	875	A4/F4	100 L4A	0.9
	29	1/32,59	724	A4/F4	112 M6A	1.3
	30	1/47,33	700	A4/F4	100 L4A	1
	38	1/37,37	553	A4/F4	100 L4A	1.1
	42	1/33,81	500	A4/F4	100 L4A	1.2
	50	1/28,40	420	A4/F4	100 L4A	1.3
	60	1/23,67	350	A3/F3	100 L4A	0.9
	70	1/20,29	300	A3/F3	100 L4A	1.1
	80	1/17,75	263	A3/F3	100 L4A	1.2
	85	1/16,71	247	A3/F3	100 L4A	1.3
	100	1/14,20	210	A3/F3	100 L4A	1.4
	120	1/11,83	175	A3/F3	100 L4A	1.5
	129	1/11,01	163	A3/F3	100 L4A	1.5
	160	1/8,88	131	A3/F3	100 L4A	1.6
	194	1/7,32	108	A3/F3	100 L4A	1.7
251	1/5,66	84	A3/F3	100 L4A	1.9	
294	1/4,83	71	A3/F3	100 L4A	2	
402	1/3,53	52	A3/F3	100 L4A	2.4	
496	1/2,86	42	A3/F3	100 L4A	2.6	



A-F TİPİ REDÜKTÖR SEÇİM TABLOSU

P : Motor gücü
n2 : Çıkış hızı
M2 : Çıkış torku
i : Redüksiyon oranı
fs : Servis faktörü

A-F TYPES SELECTION TABLE

P : Motor power
n2 : Output speed
M2 : Output torque
i : Ratio of the gearbox
fs : Operating factor

P Kw	n2 1/min	i	M2 Nm	TİP TYPE		fs
3	1	1/950	28650	A45/F45	132 S6B	1.8
	1,5	1/953,33	19100	A45/F45	100 L4B	1.1
	2	1/715	14325	A45/F45	100 L4B	1.1
	2,5	1/572	11460	A45/F45	100 L4B	1.1
	3	1/476,67	9550	A45/F45	100 L4B	1.2
	3,5	1/408,67	8186	A45/F45	100 L4B	1.2
	4	1/357,50	7163	A45/F45	100 L4B	1.2
	4,5	1/317,78	6367	A45/F45	100 L4B	1.3
	5	1/286	5730	A45/F45	100 L4B	1.3
	5,5	1/260	5209	A45/F45	100 L4B	1.3
	6	1/238,33	4775	A44/F44	100 L4B	1
	6,5	1/220	4408	A44/F44	100 L4B	1
	7	1/204,29	4093	A44/F44	100 L4B	1.1
	7,5	1/190,67	3820	A44/F44	100 L4B	1.1
	8	1/178,75	3581	A44/F44	100 L4B	1.1
	8,5	1/168,24	3371	A44/F44	100 L4B	1.1
	9	1/158,89	3183	A34/F34	100 L4B	1.2
	9,5	1/150,53	3016	A34/F34	100 L4B	1.2
	10	1/143	2865	A34/F34	100 L4B	1.2
	13	1/73,08	2204	A5/F5	132 S6B	1.8
	13	1/73,08	2204	A4/F4	132 S6B	1.1
	15	1/63,33	1910	A5/F5	132 S6B	1.8
	15	1/63,33	1910	A4/F4	132 S6B	1.1
	19	1/50	1508	A5/F5	132 S6B	1.8
	20	1/47,50	1433	A4/F4	132 S6B	1.2
	20	1/71,50	1433	A4/F4	100 L4B	0.9
	24	1/39,58	1194	A4/F4	132 S6B	1.2
	24	1/59,58	1194	A4/F4	100 L4B	0.9
	29	1/32,76	988	A4/F4	132 S6B	1.3
	30	1/47,67	955	A4/F4	100 L4B	1.1
	38	1/37,63	754	A4/F4	100 L4B	1.2
	42	1/34,05	682	A4/F4	100 L4B	1.3
	45	1/31,78	637	A4/F4	100 L4B	1.4
	50	1/28,60	573	A4/F4	100 L4B	1.5
	60	1/23,83	478	A4/F4	100 L4B	1.6
	70	1/20,43	409	A4/F4	100 L4B	1.7
	80	1/17,88	358	A4/F4	100 L4B	1.8
	85	1/16,82	337	A3/F3	100 L4B	1.8
	100	1/14,30	287	A3/F3	100 L4B	1.2
	120	1/11,92	239	A3/F3	100 L4B	1.4
129	1/11,09	222	A3/F3	100 L4B	1.5	
160	1/8,94	179	A3/F3	100 L4B	1.7	
194	1/7,37	148	A3/F3	100 L4B	1.8	
251	1/5,70	114	A3/F3	100 L4B	2	
294	1/4,86	97	A3/F3	100 L4B	2.2	
402	1/3,56	71	A3/F3	100 L4B	2.5	
496	1/2,88	58	A3/F3	100 L4B	2.8	



A-F TİPİ REDÜKTÖR SEÇİM TABLOSU

P : Motor gücü

n2 : Çıkış hızı

M2 : Çıkış torku

i : Redüksiyon oranı

fs : Servis faktörü

A-F TYPES SELECTION TABLE

P : Motor power

n2 : Output speed

M2 : Output torque

i : Ratio of the gearbox

fs : Operating factor

P Kw	n2 1/min	i	M2 Nm	TİP TYPE		fs
4	1	1/950	38200	A56/F56	132 M6A	1,9
	1,5	1/956,67	25467	A56/F56	112 M4B	1
	2	1/717,50	19100	A56/F56	112 M4B	1
	2,5	1/574	15280	A56/F56	112 M4B	1,1
	3	1/478,33	12733	A56/F56	112 M4B	1
	3,5	1/410	10914	A56/F56	112 M4B	1,1
	4	1/358,75	9550	A56/F56	112 M4B	1,2
	4,5	1/318,89	8489	A56/F56	112 M4B	1,2
	5	1/287	7640	A56/F56	112 M4B	1,3
	5,5	1/260,91	6945	A55/F55	112 M4B	1
	6	1/239,17	6367	A55/F55	112 M4B	1
	6,5	1/220,77	5877	A55/F55	112 M4B	1
	7	1/205	5457	A45/F45	112 M4B	1
	7,5	1/191,33	5093	A45/F45	112 M4B	1
	8	1/179,38	4775	A45/F45	112 M4B	1,1
	8,5	1/168,82	4494	A45/F45	112 M4B	1,1
	9	1/159,44	4244	A45/F45	112 M4B	1,2
	9,5	1/151,05	4021	A45/F45	112 M4B	1,2
	10	1/143,50	3820	A45/F45	112 M4B	1,2
	13	1/73,08	2938	A6/F6	132 M6A	1,9
	13	1/73,08	2938	A5/F5	132 M6A	1,1
	15	1/63,33	2547	A5/F5	132 M6A	1,2
	16	1/59,38	2388	A6/F6	132 M6A	2
	20	1/47,50	1910	A6/F6	132 M6A	2
	20	1/47,50	1910	A5/F5	132 M6A	1,3
	20	1/71,75	1910	A5/F5	112 M4B	0,9
	24	1/39,58	1592	A5/F5	132 M6A	1,4
	25	1/57,40	1528	A5/F5	112 M4B	1
	30	1/47,83	1273	A5/F5	112 M4B	1,1
	38	1/37,76	1005	A5/F5	112 M4B	1,2
	42	1/34,17	910	A5/F5	112 M4B	1,3
	45	1/31,89	849	A5/F5	112 M4B	1,3
	50	1/28,70	764	A5/F5	112 M4B	1,4
	60	1/23,92	637	A5/F5	112 M4B	1,5
	70	1/20,50	546	A5/F5	112 M4B	1,6
	80	1/17,94	478	A4/F4	112 M4B	1
	85	1/16,88	449	A4/F4	112 M4B	1,1
	100	1/14,35	382	A4/F4	112 M4B	1,2
125	1/11,48	306	A4/F4	112 M4B	1,4	
155	1/9,26	246	A4/F4	112 M4B	1,6	
186	1/7,72	205	A4/F4	112 M4B	1,7	
220	1/6,52	174	A3/F3	112 M4B	1,9	
240	1/5,98	159	A3/F3	112 M4B	2,1	
302	1/4,75	126	A3/F3	112 M4B	2,4	
388	1/3,70	98	A3/F3	112 M4B	2,8	



A-F TİPİ REDÜKTÖR SEÇİM TABLOSU

P : Motor gücü
n2 : Çıkış hızı
M2 : Çıkış torku
i : Redüksiyon oranı
fs : Servis faktörü

A-F TYPES SELECTION TABLE

P : Motor power
n2 : Output speed
M2 : Output torque
i : Ratio of the gearbox
fs : Operating factor

P Kw	n2 1/min	i	M2 Nm	TİP TYPE		fs
5.5	2	1/722,50	26263	A67/F67	132 S4C	1.6
	2.5	1/578	21010	A67/F67	132 S4C	1.6
	3	1/481,67	17508	A67/F67	132 S4C	1.6
	3.5	1/412,86	15007	A67/F67	132 S4C	1.6
	4	1/361,25	13131	A67/F67	132 S4C	1.7
	4.5	1/321,11	11672	A67/F67	132 S4C	1.7
	5	1/289	10505	A66/F66	132 S4C	1
	5.5	1/262,73	9550	A66/F66	132 S4C	1
	6	1/240,83	8754	A66/F66	132 S4C	1
	6.5	1/222,31	8081	A66/F66	132 S4C	1.1
	7	1/206,43	7504	A56/F56	132 S4C	0.9
	7.5	1/192,67	7003	A56/F56	132 S4C	0.9
	8	1/180,63	6566	A56/F56	132 S4C	1
	8.5	1/170	6179	A56/F56	132 S4C	1
	9	1/160,56	5836	A56/F56	132 S4C	1
	9.5	1/152,11	5529	A56/F56	132 S4C	1
	10	1/144,50	5253	A56/F56	132 S4C	1.1
	13	1/73,85	4040	A6/F6	132 M6B	1.6
	16	1/60	3283	A6/F6	132 M6B	1.6
	20	1/72,25	2626	A6/F6	132 S4C	1.1
	21	1/45,71	2501	A6/F6	132 M6B	1.6
	26	1/36,92	2020	A6/F6	132 M6B	1.7
	26	1/55,58	2020	A6/F6	132 S4C	1.2
	32	1/45,16	1641	A6/F6	132 S4C	1.3
	40	1/36,13	1313	A6/F6	132 S4C	1.4
	50	1/28,90	1051	A6/F6	132 S4C	1.5
	65	1/22,23	808	A6/F6	132 S4C	1.6
	80	1/18,06	657	A6/F6	132 S4C	1.7
	85	1/17	618	A6/F6	132 S4C	1.8
	100	1/14,45	525	A5/F5	132 S4C	1.3
	125	1/11,56	420	A5/F5	132 S4C	1.4
	155	1/9,32	339	A5/F5	132 S4C	1.6
186	1/7,77	282	A5/F5	132 S4C	1.8	
220	1/6,57	239	A5/F5	132 S4C	2	
240	1/6,02	219	A5/F5	132 S4C	2.2	
302	1/4,78	174	A5/F5	132 S4C	2.5	
388	1/3,72	135	A5/F5	132 S4C	2.8	
7.5	2.5	1/580	28650	A67/F67	132 M4B	1.3
	3	1/483,33	23875	A67/F67	132 M4B	1.3
	3.5	1/414,29	20464	A67/F67	132 M4B	1.3
	4	1/362,50	17906	A67/F67	132 M4B	1.4
	4.5	1/322,22	15917	A67/F67	132 M4B	1.4
	5	1/290	14325	A67/F67	132 M4B	1.4
	5.5	1/263,64	13023	A67/F67	132 M4B	1.5
	6	1/241,67	11938	A67/F67	132 M4B	1.5
	6.5	2/223,08	11019	A67/F67	132 M4B	1.5
	7.5	1/193,33	9550	A67/F67	132 M4B	1.5



A-F TİPİ REDÜKTÖR SEÇİM TABLOSU

P : Motor gücü
n2 : Çıkış hızı
M2 : Çıkış torku
i : Redüksiyon oranı
fs : Servis faktörü

A-F TYPES
SELECTION TABLE

P : Motor power
n2 : Output speed
M2 : Output torque
i : Ratio of the gearbox
fs : Operating factor

P Kw	n2 1/min	i	M2 Nm	TİP TYPE		fs
7,5	8	1/181,25	8953	A67/F67	132 M4B	1.5
	9	1/161,11	7958	A67/F67	132 M4B	1.5
	10	1/145	7163	A67/F67	132 M4B	1.6
	13	1/73,85	5510	A6/F6	160 M6B	1
	15	1/64	4775	A7/F7	160 M6B	2.1
	16	1/60	4477	A6/F6	160 M6B	1.1
	18	1/53,33	3979	A7/F7	160 M6B	2.1
	20	1/48	3581	A6/F6	160 M6B	1.4
	24	1/40	2984	A7/F7	160 M6B	2.2
	25	1/38,40	2865	A6/F6	160 M6B	1.4
	25	1/58	2865	A6/F6	132 M4B	1
	30	1/48,33	2388	A6/F6	132 M4B	1
	40	1/36,25	1791	A6/F6	132 M4B	1.1
	50	1/29	1433	A6/F6	132 M4B	1.2
	65	1/22,31	1102	A6/F6	132 M4B	1.3
	80	1/18,13	895	A6/F6	132 M4B	1.4
	85	1/17,06	843	A6/F6	132 M4B	1.5
	100	1/14,50	716	A6/F6	132 M4B	1.6
	125	1/11,60	573	A6/F6	132 M4B	1.7
	155	1/9,35	462	A5/F5	132 M4B	1.1
	155	1/9,35	462	A6/F6	132 M4B	1.9
	186	1/7,80	385	A5/F5	132 M4B	1.3
	220	1/6,59	326	A5/F5	132 M4B	1.5
	240	1/6,04	298	A5/F5	132 M4B	1.6
302	1/4,80	237	A5/F5	132 M4B	1.8	
388	1/3,74	185	A5/F5	132 M4B	2.4	
11	15	1/64	7003	A7/F7	160 L6B	1.1
	18	1/53,33	5836	A7/F7	160 L6B	1.1
	20	1/48	5253	A7/F7	160 L6B	1.1
	25	1/38,40	4202	A7/F7	160 L6B	1.2
	25	1/58	4202	A7/F7	160 M4B	0.8
	30	1/32	3502	A7/F7	160 L6B	1.3
	30	1/48,33	3502	A7/F7	160 M4B	0.9
	35	1/41,43	3001	A7/F7	160 M4B	1
	40	1/36,25	2626	A7/F7	160 M4B	1.1
	45	1/32,22	2334	A7/F7	160 M4B	1.2
	50	1/29	2101	A7/F7	160 M4B	1.3
	57	1/25,44	1843	A7/F7	160 M4B	1.3
	65	1/22,31	1616	A7/F7	160 M4B	1.4
	70	1/20,71	1501	A7/F7	160 M4B	1.5
	78	1/18,59	1347	A7/F7	160 M4B	1.6
	80	1/18,13	1313	A7/F7	160 M4B	1.6
	100	1/14,50	1051	A7/F7	160 M4B	1.7
	125	1/11,60	840	A6/F6	160 M4B	1.1
	152	1/9,54	691	A6/F6	160 M4B	1.3
	199	1/7,29	528	A6/F6	160 M4B	1.5
	252	1/5,75	417	A6/F6	160 M4B	1.8
	317	1/4,57	331	A6/F6	160 M4B	2.2



A-F TİPİ REDÜKTÖR SEÇİM TABLOSU

P : Motor gücü

n2 : Çıkış hızı

M2 : Çıkış torku

i : Redüksiyon oranı

fs : Servis faktörü

A-F TYPES SELECTION TABLE

P : Motor power

n2 : Output speed

M2 : Output torque

i : Ratio of the gearbox

fs : Operating factor

P Kw	n2 1/min	i	M2 Nm	TİP TYPE		fs
15	15	1/64,33	9550	A7/F7	180 L6A	1,4
	18	1/53,61	7958	A7/F7	180 L6A	1,5
	20	1/48,25	7163	A7/F7	180 L6A	1,5
	25	1/38,60	5730	A7/F7	180 L6A	1,6
	25	1/58	5730	A7/F7	160 L4A	1,1
	30	1/32,17	4775	A7/F7	180 L6A	1,6
	30	1/48,33	4775	A7/F7	160 L4A	1,1
	35	1/41,43	4093	A7/F7	160 L4A	1,2
	40	1/36,25	3581	A7/F7	160 L4A	1,3
	45	1/32,22	3183	A7/F7	160 L4A	1,3
	50	1/29	2865	A7/F7	160 L4A	1,4
	57	1/25,44	2513	A7/F7	160 L4A	1,5
	65	1/22,31	2204	A7/F7	160 L4A	1,6
	70	1/20,71	2046	A7/F7	160 L4A	1,6
	78	1/18,59	1837	A7/F7	160 L4A	1,7
	85	1/17,06	1685	A7/F7	160 L4A	1,8
	100	1/14,50	1433	A7/F7	160 L4A	1,9
	130	1/11,15	1102	A7/F7	160 L4A	2
165	1/8,79	868	A7/F7	160 L4A	2,1	
205	1/7,07	699	A7/F7	160 L4A	2,2	
250	1/5,80	573	A7/F7	160 L4A	2,3	
18,5	35	1/41,43	5048	A7/F7	180 M4B	0,9
	40	1/36,25	4417	A7/F7	180 M4B	0,9
	45	1/32,22	3926	A7/F7	180 M4B	1
	50	1/29	3534	A7/F7	180 M4B	1
	57	1/25,44	3100	A7/F7	180 M4B	1,1
	65	1/22,31	2718	A7/F7	180 M4B	1,1
	70	1/20,71	2524	A7/F7	180 M4B	1,2
	78	1/18,59	2265	A7/F7	180 M4B	1,2
	85	1/17,06	2079	A7/F7	180 M4B	1,2
	100	1/14,50	1767	A7/F7	180 M4B	1,3
	130	1/11,15	1359	A7/F7	180 M4B	1,4
	165	1/8,79	1071	A7/F7	180 M4B	1,5
	205	1/7,07	862	A7/F7	180 M4B	1,8
250	1/5,8	707	A7/F7	180 M4B	2,2	
22	57	1/25	3686	A7/F7	180 L4B	0,9
	65	1/22,3	3232	A7/F7	180 L4B	1
	70	1/20,7	3001	A7/F7	180 L4B	1
	78	1/18,6	2694	A7/F7	180 L4B	1,1
	85	1/17,06	2472	A7/F7	180 L4B	1,1
	100	1/14,5	2101	A7/F7	180 L4B	1,2
	130	1/11,15	1616	A7/F7	180 L4B	1,3
	165	1/8,78	1273	A7/F7	180 L4B	1,4
	205	1/7,07	1025	A7/F7	180 L4B	1,8
250	1/5,8	840	A7/F7	180 L4B	2,1	



HELİSEL DİŞLİ İKİ KADEMELİ REDÜKTÖR HELICAL GEARED MOTORS DOUBLE REDUCTION

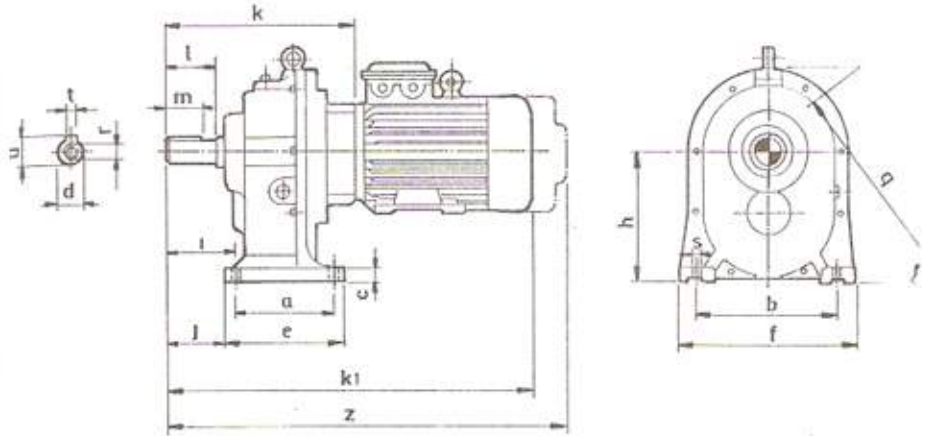

TIP TYPE	a	b	c	d (H7)	e	f	h	i	j	k	kl	l	m	p	r	s	t	u	z	Ağırlık Kg Weight
A1	115	158	20	25	148	190	122	61,5	65	222	403	50	35	205	M8	10	8	28	526	23
A2	128	170	20	28	159	207	132	92,5	77	200	414	60	45	220	M8	12	8	31	537	26
A3	140	192	22	38	177	240	160	112,5	94	272	498	75	60	285	M10	12	10	41,1	614	38
A4	160	231	25	48	217	290	207	136	110	319	583	100	70	333	M12	16	14	51,6	699	63
A5	175	254	35	48	225	310	223	138	113	338	655	100	70	355	M12	16	14	51,6	771	93
A6	200	276	35	60	268	350	256	154	120	370	806	110	85	410	M14	22	16	63,9	922	161
A7	280	358	50	70	356	450	316	158	135	466	945	130	90	513	M16	22	20	74,7	1070	267

NOT : "z" ölçüsü frenli redüktöre aittir. Ağırlık motor tipine göre değişkendir.

NOTE : Dimension "z" is for motor with brake. When motors types changes the gearboxes weight chances.



AYAKLI ÇİFT MOTORLU REDÜKTÖR
FOOT MOUNTING DOUBLE STEGE TYPE WITH MOTOR

HELICAL GEARED MOTOR, TRIBLE REDUCTION FOOT MOUNTED

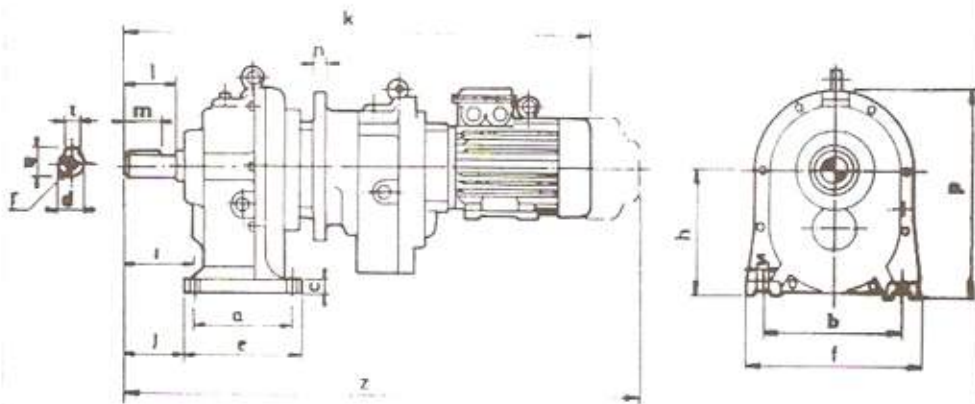

TİP TYPE	a	b	c	d (H7)	e	f	h	i	j	k	l	m	n	p	r	s	t	u	z	Ağırlık Kg Weight
A11	115	158	20	25	148	190	122	81,5	65	581	50	35	16	205	M8	10	8	28	703,5	35,5
A22	128	170	20	28	159	207	132	92,5	77	618	60	45	16	220	M8	12	8	31	740,5	42,5
A33	140	192	22	38	177	240	160	113	94	698	75	60	18	265	M10	12	10	41,1	820,5	70,5
A44	160	231	25	48	217	290	207	136	110	844	100	70	18	333	M12	16	14	51,6	960	120
A55	175	254	35	48	225	310	223	138	113	954	100	70	18	355	M12	16	14	51,6	1070	149
A66	200	276	35	60	268	350	256	154	120	1068	110	85	22	410	M14	22	16	63,9	1184	228,5
A77	280	358	50	70	356	450	316	158	135	1200	130	90	22	513	M16	22	20	74,7	1316	300

NOT : "z" ölçüsü frenli redüktöre aittir. Ağırlık motor tipine göre değişkendir.

NOTE : Dimension "z" is for motor with brake. When motors types changes the gearboxes weight changes.



AYAKLI ÇİFT MOTORLU REDÜKTÖR
FOOT MOUNTING DOUBLE STAGE TYPE WITH MOTOR

HELICAL GEARED MOTOR, TRIBLE REDUCTION FOOT MOUNTED

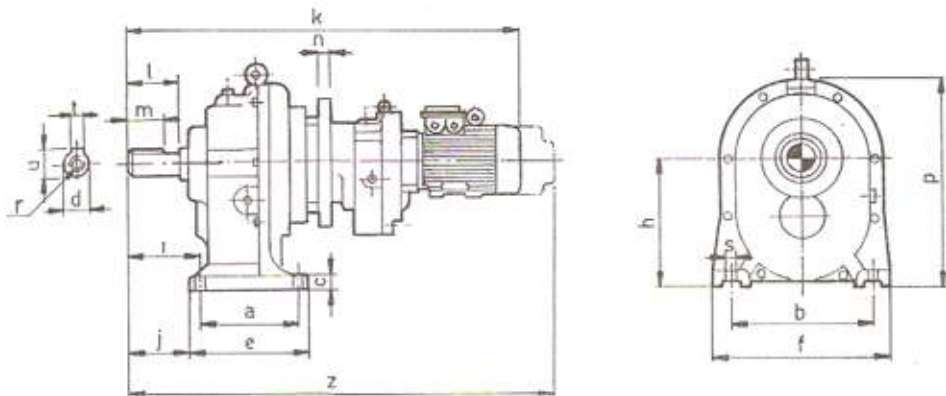

TİP TYPE	a	b	c	d (H7)	e	f	h	i	j	k	l	m	n	p	r	s	t	u	z	Ağırlık Kg Weight
A12	128	170	20	28	159	207	132	92,5	77	601	60	45	16	220	M8	12	8	31	723	42,5
A23	140	192	22	38	177	240	160	112,5	94	673	75	60	18	265	M10	12	10	41,1	795	70,5
A34	160	231	25	48	217	290	207	136	110	813	100	70	18	333	M12	16	14	51,6	929	120
A45	175	254	35	48	225	310	223	138	113	905	100	70	18	355	M12	16	14	51,6	1021	149
A56	200	276	35	60	268	350	256	154	120	997	110	85	22	410	M14	22	16	63,9	1113	228,5
A67	280	358	50	70	356	450	316	158	135	1125	130	90	22	513	M16	22	20	74,7	1241	300

NOT : "z" ölçüsü frenli redüktöre aittir. Ağırlık motor tipine göre değişkendir.

NOTE : Dimension "z" is for motor with brake. When motors types the gearboxes weight chances.



HELİSEL DİŞLİ İKİ KADEMELİ T-TİPİ REDÜKTÖR

HELICAL GEARBOXES, DOUBLE REDUCTION FREE INPUT SHAFT T-TYPE

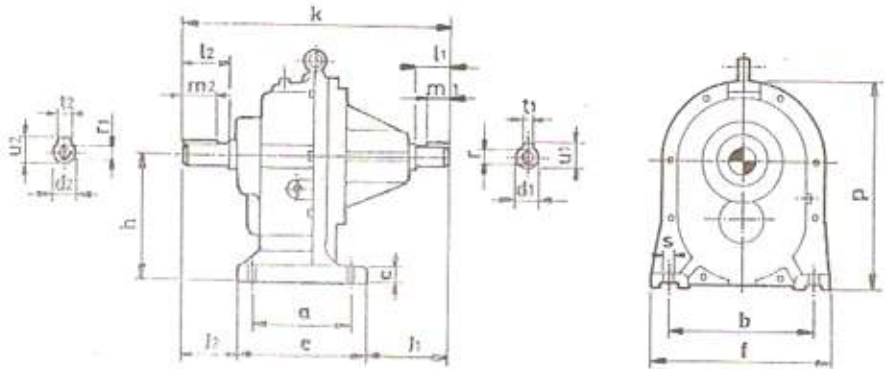

TIP TYPE	a	b	c	d1 (H7)	d2 (H7)	e	f	h	J1	J2	k	l1	l2	m1	m2	p	r	r1	s	t1	t2	u1	u2	Ağırlık Kg Weight
AT1	115	158	20	14	25	148	190	122	67	65	280	40	50	20	35	205	M6	M8	10	5	8	16,2	28	17
AT2	128	170	20	18	28	159	207	132	150	77	386	55	60	40	45	220	M6	M8	12	6	8	20,6	31	18
AT3	140	192	22	25	38	177	240	160	181	94	452	62	75	45	60	265	M8	M10	12	8	10	28	41,1	31
AT4	160	231	25	28	48	217	290	207	192	110	519	75	100	45	70	333	M10	M12	16	8	14	31	51,6	53
AT5	175	254	35	32	48	225	310	223	207	113	545	75	100	60	70	355	M10	M12	16	10	14	35,1	51,6	70
AT6	200	276	35	38	60	268	350	256	207	120	595	90	110	60	85	410	M12	M14	22	10	16	41,1	63,9	100
AT7	280	358	50	42	70	356	450	316	247	135	658	100	130	60	90	513	M16	M16	22	12	20	45,2	74,7	200



AYAKLI ÇİFTLİ MOTORSUZ REDÜKTÖR FOOT MOUNTING DOUBLE STAGE TYPE WITHOUT MOTOR

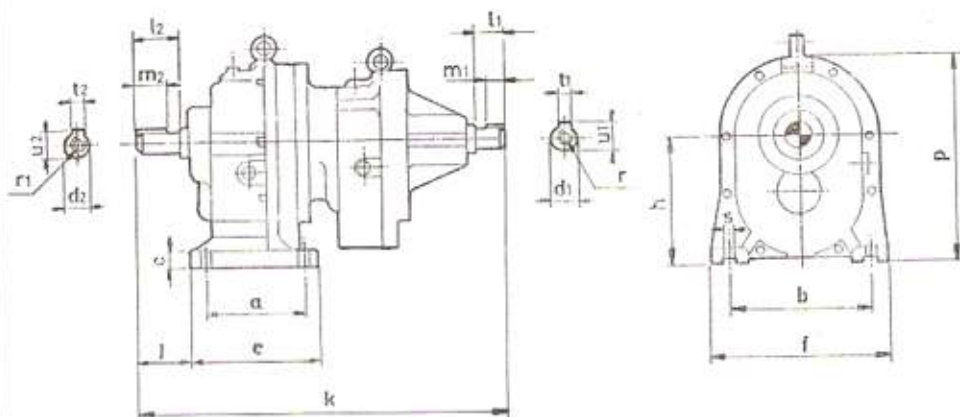

TİP TYPE	a	b	c	d1 (H7)	d2 (H7)	e	f	h	j	k	l1	l2	m1	m2	p	r	r1	s	t1	t2	u1	u2	Ağırlık Kg Weight
AT11	115	158	20	14	25	148	190	122	65	485	40	50	20	35	205	M6	M8	10	5	8	16,2	28	30
AT22	128	170	20	18	28	159	207	132	77	511	55	60	40	45	220	M6	M8	12	6	8	20,6	31	35
AT33	140	192	22	25	38	177	240	160	94	611	62	75	45	60	265	M8	M10	12	8	10	28	41,1	50
AT44	160	231	25	28	48	217	290	207	110	704	75	100	45	70	333	M10	M12	16	8	14	31	51,6	75
AT55	175	254	35	32	48	225	310	223	113	749	75	100	60	70	355	M10	M12	16	10	14	35,1	51,6	100
AT66	200	276	35	38	60	268	350	256	120	857	90	110	60	85	410	M12	M14	22	10	16	41,1	63,9	170
AT77	280	358	50	42	70	356	450	316	135	1000	100	130	60	90	513	M16	M16	22	12	20	45,2	74,7	300

AYAKLI ÇİFTLİ MOTORSUZ REDÜKTÖR
FOOT MOUNTING DOUBLE STAGE TYPE WITHOUT MOTOR
WITH FREE INPUT SHAFT TYPE-T TRIPLE REDUCTION

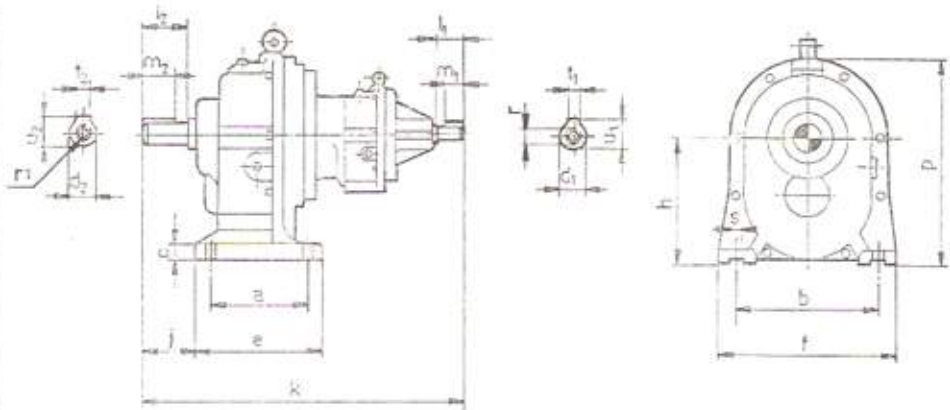

TIP TYPE	a	b	c	d1 (H7)	d2 (H7)	e	f	h	J	k	l1	l2	m1	m2	p	r	r1	s	t1	t2	u1	u2	Ağırlık Kg Weight
AT12	128	170	20	14	28	159	207	132	77	473	40	60	20	45	220	M6	M8	12	5	8	16,2	31	23
AT23	140	192	22	18	38	177	240	160	94	582	55	75	40	60	265	M6	M10	12	6	10	20,6	41,1	26
AT34	160	231	25	25	48	217	290	207	110	675	62	100	45	70	333	M8	M12	16	8	14	28	51,6	40
AT45	175	254	35	28	48	225	310	223	113	705	75	100	45	70	355	M10	M12	16	8	14	31	51,6	65
AT56	200	276	35	32	60	268	350	256	120	764	75	110	60	85	410	M12	M14	22	10	16	35,1	63,9	85
AT67	280	358	50	38	70	356	450	316	135	842	90	130	60	90	513	M16	M16	22	10	20	41,2	74,7	135

HELİSEL DİŞLİ İKİ KADEMELİ, FLANŞLI REDÜKTÖR HELICAL GEARED MOTORS DOUBLE REDUCTION, FLANGE MOUNTING

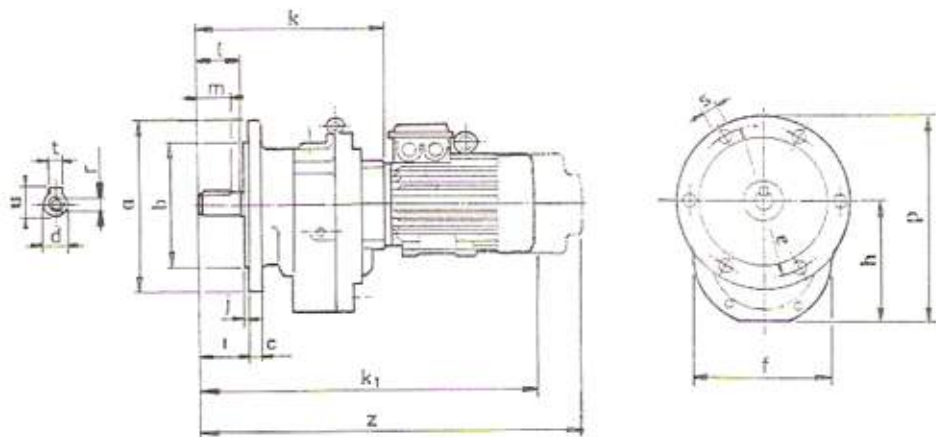

TİP TYPE	a	b	c	d (H7)	e	f	h	i	j	k	k1	l	m	p	r	s	t	u	z	Ağırlık Kg Weight
F1	150	90	16	25	125	161	120	59	3	230	424	50	35	200	M8	10	8	28	548	23
F2	185	130	16	28	158	180	130	69	3	259	449	60	45	222	M8	11	8	31	572	27
F3	210	150	18	35	185	210	160	87	5	315	541	75	60	265	M10	12	10	38,1	664	47
F4	250	180	20	48	225	250	205	113	5	383	647	100	70	330	M12	15	14	51,6	763	78
F5	285	180	20	48	250	272	218	118	5	404	721	100	70	350	M12	15	14	51,6	837	101
F6	320	240	22	55	290	310	255	141	5	469	905	110	85	415	M14	18	16	63,9	1021	173
F7	420	305	35	70	365	390	310	165	5	478	1033	130	90	510	M16	23	20	74,7	1332	225

NOT : "z" ölçüsü frenli redüktöre aittir. Ağırlık motor tipine göre değişkendir.

NOTE : Dimension "z" is for motor with brake. When motors types changes the gearboxes weight chances.

F1, F2 tip redüktör flanşlı üzerinde 4 adet bağlantı deliği vardır.

There are four connecting hole on the gearbox flange F1 and F2 type



FLANŞLI, ÇİFTLİ MOTORLU FLANGE MOUNTING DOUBLE STAGE TYPE WITH MOTOR

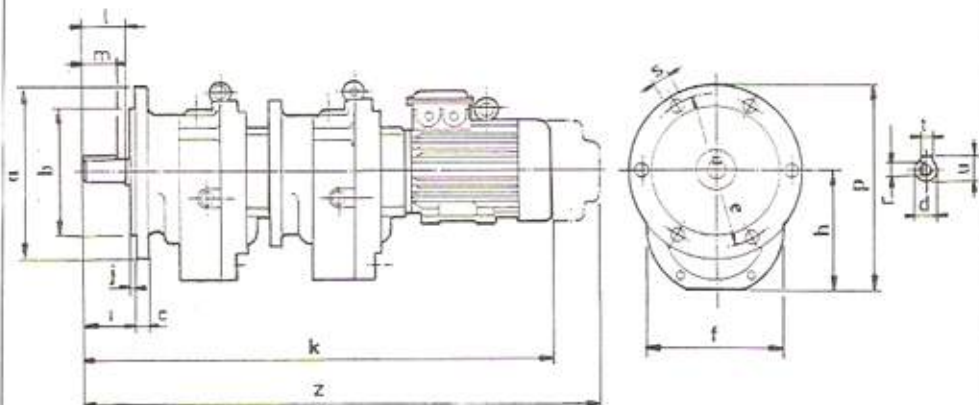

TIP TYPE	a	b	c	d (H7)	e	f	h	i	j	k	l	m	p	r	s	t	u	z	Ağırlık Kg Weight
F11	150	90	16	25	125	161	120	59	3	665	50	35	200	M8	10	8	28	785	33
F22	185	130	16	28	158	180	130	69	3	716	60	45	222	M8	11	8	31	838	44
F33	210	150	18	35	185	210	160	87	5	828	75	60	265	M10	12	10	38,1	950	74
F44	250	180	20	48	225	250	205	113	5	1026	100	70	330	M12	15	14	51,6	1142	130
F55	285	180	20	48	250	272	218	118	5	1133	100	70	350	M12	15	14	51,6	1249	162
F66	320	240	22	55	290	310	255	141	5	1289	110	85	415	M14	18	16	63,9	1405	241
F77	420	305	35	70	365	390	310	165	5	1450	130	90	510	M16	23	20	74,7	1950	285

NOT : "z" ölçüsü frenli redüktöre aittir. Ağırlık motor tipine göre değişkendir.

NOTE : Dimension "z" is for motor with brake. When motors types changes the gearboxes weight changes.

F1, F2 tip redüktör flanşlı üzerinde 4 adet bağlantı deliği vardır.

There are four connecting hole on the gearbox flange F11 and F22 type



**FLANŞLI, ÇİTLİ MOTORLU
FLANGE MOUNTING DOUBLE STAGE TYPE WITH MOTOR**

HELICAL GEARED MOTOR, TRIPLE REDUCTION, FLANGE MOUNTED

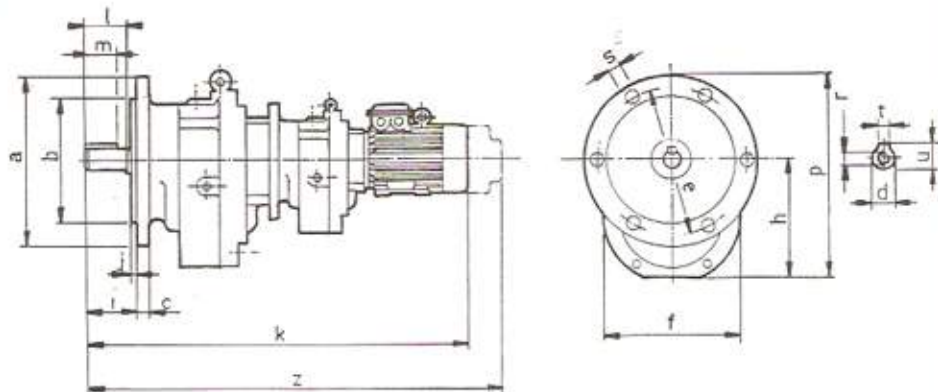

TIP TYPE	a	b	c	d (H7)	e	f	h	i	j	k	l	m	p	r	s	t	u	z	Ağırlık Kg Weight
F12	185	130	16	28	158	180	130	69	3	695	60	45	222	M8	11	8	31	817	44
F23	210	150	18	35	185	210	160	87	5	785	75	60	265	M10	12	10	38,1	907	74
F34	250	180	20	48	225	250	205	100	5	965	100	70	330	M12	15	14	51,6	1081	130
F45	285	180	20	48	250	272	218	118	5	1070	100	70	350	M12	15	14	51,6	1186	162
F56	320	240	22	55	290	310	255	141	5	1200	110	85	415	M14	18	16	63,9	1316	241
F67	420	305	35	70	365	390	310	165	5	1425	130	90	510	M16	23	20	74,7	1610	260

NOT : "z," ölçüsü frenli redüktöre aittir. Ağırlık motor tipine göre değişkendir.

NOTE : Dimension "z," is for motor with brake. When motors types changes the gearboxes weight chances.

F1, F2 tip redüktör flanşlı üzerinde 4 adet bağlantı deliği vardır.

There are four connecting hole on the gearbox flange F12 type



**FLANŞLI TİP MOTORSUZ REDÜKTÖR
FLANGE MOUNTING TYPE WITHOUT MOTOR**

**HELİSEL DİŞLİ İKİ KADEMELİ, FT TİPİ REDÜKTÖR
HELICAL GEARBOXES DOUBLE REDUCTION FREE INPUT SHAFT FT TYPE**

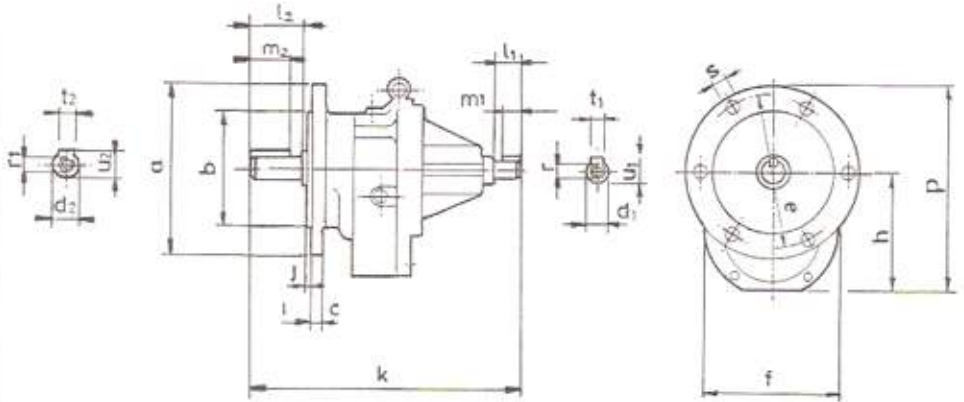

TİP TYPE	a	b	c	d1 (H7)	d2 (H7)	e	f	h	i	j	k	l1	l2	m1	m2	p	r	r1	s	t1	t2	u1	u2	Ağırlık Kg Weight
FT1	150	90	16	14	25	125	161	120	59	3	390	40	50	20	35	200	M6	M8	10	5	8	16,1	28	15
FT2	185	130	16	18	28	158	180	130	69	3	390	55	60	40	45	222	M6	M8	11	6	8	20,6	31	23
FT3	210	150	18	25	35	185	210	160	87	5	471	62	75	45	60	265	M8	M10	12	8	10	28	38,1	38
FT4	250	180	20	28	48	225	250	205	115	5	548	75	100	45	70	330	M10	M12	15	8	14	31	51,6	62
FT5	285	180	20	32	48	250	275	218	118	5	584	75	100	60	70	350	M10	M12	15	10	14	35,1	51,6	71
FT6	320	240	22	38	55	290	310	255	141	5	679	90	110	60	85	415	M12	M14	18	10	16	41,1	58,6	101
FT7	420	305	35	42	70	365	390	310	165	5	830	100	130	60	90	510	M16	M16	23	12	20	45,2	74,7	180

FT1, FT2 tip redüktör flanşı üzerinde 4 adet bağlantı deliği vardır.
There are four connecting hole on the, gearbox flange FT1 and FT2 type

FLANŞLI ÇİFTLİ MOTORSUZ REDÜKTÖR FLANGE MOUNTING DOUBLE STAGE TYPE WITHOUT MOTOR

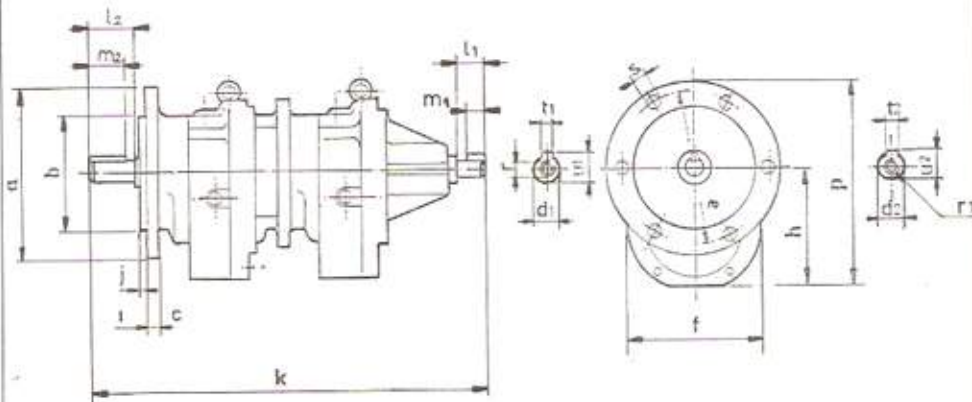

TIP TYPE	a	b	c	d1 (H7)	d2 (H7)	e	f	h	i	j	k	l1	l2	m1	m2	p	r	r1	s	t1	t2	u1	u2	Ağırlık Kg Weight
FT11	150	90	16	14	25	125	161	120	59	3	545	40	50	20	35	200	M6	M8	10	5	8	16,1	28	35
FT22	185	130	16	18	28	158	180	130	69	3	648	55	60	40	45	222	M6	M8	11	6	8	20,6	31	40
FT33	210	150	18	25	35	185	210	160	87	5	785	62	75	45	60	265	M8	M10	12	8	10	28	38,1	65
FT44	250	180	20	28	48	225	250	205	115	5	931	75	100	45	70	330	M10	M12	15	8	14	31	51,6	110
FT55	285	180	20	32	48	250	275	218	118	5	988	75	100	60	70	350	M10	M12	15	10	14	35,1	51,6	180
FT66	320	240	22	38	55	290	310	255	141	5	1148	90	110	60	85	415	M12	M14	18	10	16	41,1	58,6	350
FT77	420	305	35	42	70	365	390	310	165	5	1210	100	130	60	90	510	M16	M16	23	12	20	45,2	74,7	420

FT11, FT22 tip redüktör flansı üzerinde 4 adet bağlantı deliği vardır.
There are four connecting hole on the, gearbox flange FT11 and FT22 type



FLANSLI ÇİTLİ MOTORSUZ REDÜKTÖR FLANGE MOUNTING DOUBLE STAGE TYPE WITHOUT MOTOR

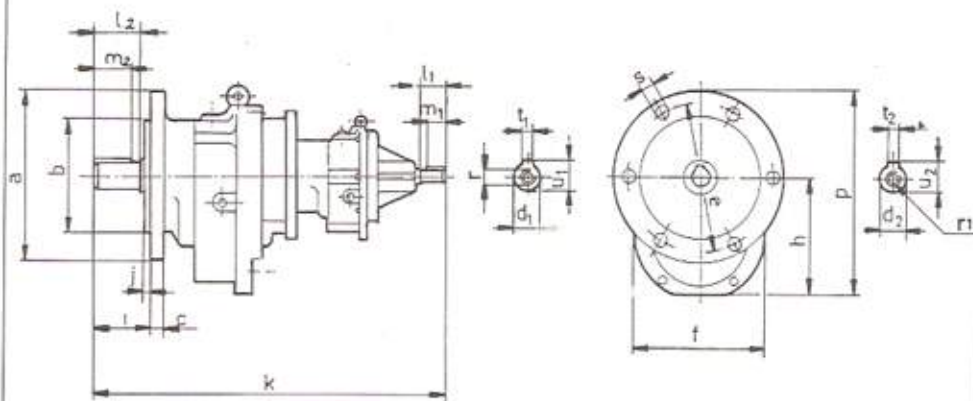

TİP TYPE	a	b	c	d1 (H7)	d2 (H7)	e	f	h	i	j	k	l1	l2	m1	m2	p	r	r1	s	t1	t2	u1	u2	Ağırlık Kg Weight
FT12	185	130	16	14	28	158	180	130	69	3	580	40	60	20	45	222	M6	M8	11	5	8	16,1	31	25
FT23	210	150	18	18	35	185	210	160	87	5	660	55	75	40	60	265	M6	M10	12	6	10	20,6	38,1	30
FT34	250	180	20	25	48	225	250	205	115	5	780	62	100	45	70	330	M8	M12	15	8	14	28	51,6	50
FT45	285	180	20	28	48	250	275	218	118	5	855	75	100	45	70	350	M10	M12	15	8	14	31	51,6	86
FT56	320	240	22	32	55	290	310	255	141	5	965	75	110	60	85	415	M10	M14	18	10	16	35,1	58,6	125
FT67	420	305	35	38	70	365	390	310	165	5	1210	90	130	60	90	510	M12	M16	23	10	20	41,1	74,7	200

FT12 tip redüktör flanşı üzerinde 4 adet bağlantı deliği vardır.
There are four connecting hole on the, gearbox flange FT12 type

